

**COMMERCIAL TANKLESS
WATER HEATER**

REGENT™

COMMERCIAL TANKLESS WATER HEATER

3 SIZES: 500,000; 750,000 & 1,000,000 BTU/HR

DOE 2026 COMPLIANT - UP TO
97% THERMAL EFFICIENCY

EXCLUSIVE CONDENSING STAINLESS STEEL
HEAT EXCHANGER

UP TO 25:1 TURNDOWN RATIO

REAL-TIME COMBUSTION FEEDBACK AND
CONTROL WITH O₂ SENSING

HINGED DOOR WITH LIFT-OFF FOR EASY
ACCESS & SERVICEABILITY

DIRECT VENT FLEXIBILITY UP TO 200 FT

SMART TOUCH™

WITH CASCADE SEQUENCER
CASCADE UP TO 8 UNITS FOR UP
TO 200:1 SYSTEM TURNDOWN



REGENT™

COMMERCIAL TANKLESS WATER HEATER

The Regent™ tankless water heater sets a new standard for combustion technology, temperature delivery and scale free operation. Its exclusive stainless-steel heat exchanger and internal circulating pump deliver high-velocity water flow through the heat exchanger, ensuring clean operation and consistent performance across a wide range of demands. With cold water maintained in secondary coils, Regent achieves full condensing operation and meets the DOE 2026 96% thermal efficiency requirement. Designed for high-capacity applications, it operates with virtually no water-side pressure drop up to 50 GPM, making it the ideal solution for commercial applications that demand precision, durability, and energy savings.



PRECISE TEMPERATURE MANAGEMENT

Regent delivers exceptional outlet temperature stability by using predictive feedforward and quick reacting feedback logic to deliver consistent hot water even under varying demand conditions. Thanks to advanced Smart Touch™ controls and an ultrasonic flow sensor, Regent responds in seconds to maintain precise temperature accuracy within $\pm 4^\circ\text{F}$.

Whether for a single shower or 100 at once, Regent tankless commercial water heater is ready to meet your needs, in an instant!

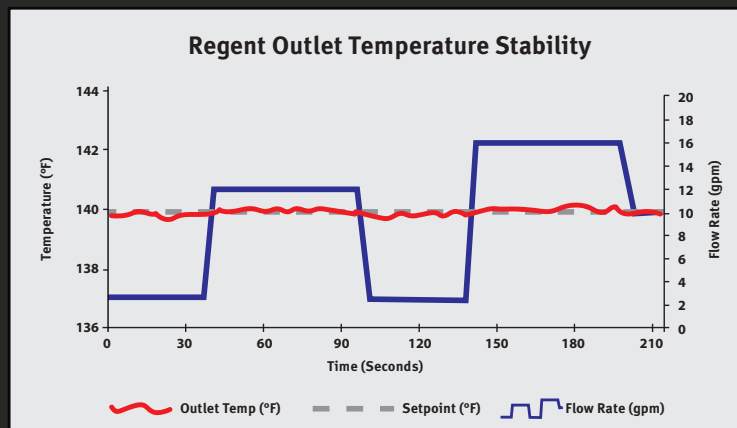

ADVANCED COMBUSTION TECHNOLOGY

With RealTime O₂ Trim, this combustion technology features feed-forward and feed-back data that ultimately delivers a targeted combustion O₂ range. Commissioning trim allows the user to program the optimal O₂ setting and patent-pending learned trim delivers consistent performance based on past environmental data. The long-lasting O₂ sensor delivers an accurate and dependable combustion system. The system ensures optimal fuel-air ratio to maintain the highest efficiency.

SCALE FREE OPERATION

Regent builds on Lochinvar's long-standing history of The Better Way to maintain scale-free operation. By utilizing an exclusively designed heat exchanger, Regent incorporates primary heat exchanger coil recirculation to maintain optimal water velocities. This allows for clean operation (up to 15 grains per gallon (gpg) hardness) without the need for water treatment.

LochinvarTM SMART TOUCH

Full color 10" Capacitive Touch LCD display

Integrates directly into a Building Automation System via Modbus or BACnet

Built-in cascade sequencer for cascading up to 8 same size units

Converts from Natural to LP with commissioning (1M requires mixer shipped with unit)



24" clearance



24" clearance



Not to scale. For reference only.

ULTRASONIC FLOW SENSOR

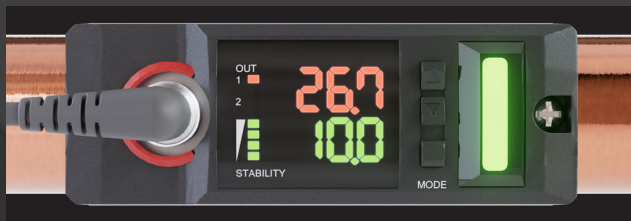

Measures water flow with high frequency sound waves

When the flow rate increases, the signal is accelerated, providing an instantaneous signal to adjust fuel rates

No leak points with clamp-on, non-intrusive design for easy service

Increased reliability without moving parts

REGENT™ COMMERCIAL TANKLESS WATER HEATER DIMENSIONS AND SPECIFICATIONS

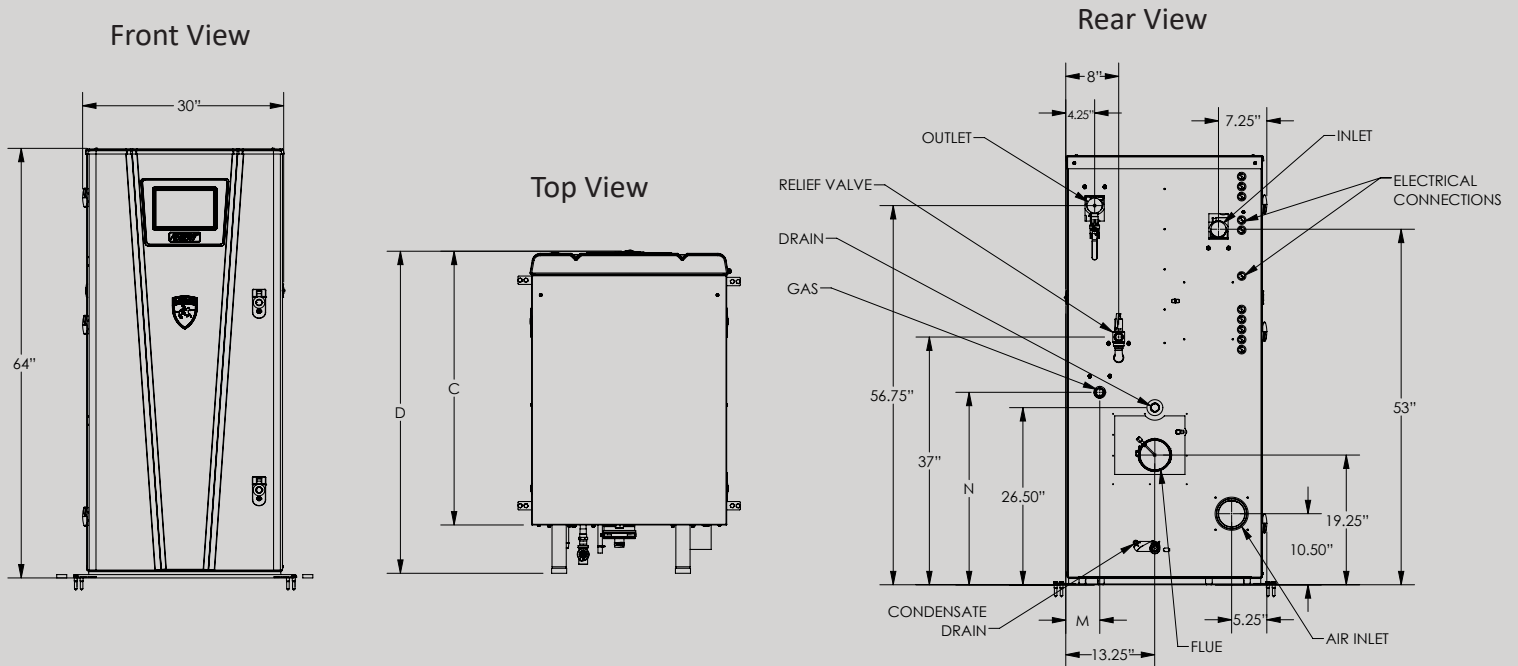

REGENT MODELS DIMENSIONS AND SPECIFICATIONS											
Model Number	BTU/HR Input	Thermal Efficiency	GPH 100°F Rise	Gas Conn.	Water Conn.	Air Inlet	Vent Size	C	D	M	N
IWH0500N	500,000	96%	576	1"	2"	4"	4"	40-3/4"	48"	5"	28-3/4"
IWH0750N	750,000	97%	864	1"	2"	6"	6"	51-1/4"	58-1/2"	5-1/2"	29-3/4"
IWH1000N	1,000,000	97%	1,152	1-1/2"	2"	6"	6"	57-3/4"	67"	5-1/2"	30-1/2"

Notes: change 'N' to 'L' at end of model number for LP gas models. Add - 8647 at the end of model number for Altitude models.

STANDARD FEATURES

- Smart Touch™ Control
- Stainless Steel Water Tube Heat Exchanger
- Turndown 500k- 12.5:1, 750k - 18.75:1, 1M - 25:1
- Real-Time Combustion Feedback System with O₂ Sensing
- ASME Pressure Relief Valve
- Inlet & Outlet Temperature Sensors
- Stainless Steel Circulating Pump
- Building Recirculation Pump Relay Contacts
- ENERGY STAR® Certified
- Low NOX complies with SCAQMD
- Indoor / Outdoor (with kit)
- Category IV Venting up to 200 feet
- 10 Year Limited Warranty Heat Exchanger (5 yr pro-rated)
- 1 Year Parts Warranty (See warranty for full details)

FACTORY INSTALLED OPTIONS

- BACnet MSTP Communications
- Modbus RTU Communications
- High & Low Gas Pressure Switches w/Manual Reset

SMART TOUCH CONTROL FEATURES

- 10" Full Color Capacitive Touchscreen LCD Display
- Built-in Cascading for up to 8 Same Size Water Heaters
- Building Automation Integration
- Password Security
- Inlet & Outlet Temperature Readout
- Time Clock
- Data Logging:
 - > Runtime tracking
 - > Ignition Attempts
 - > Last 10 Lockouts
 - > Data Graphs
- Real-Time Diagnostic Feedback

CODES AND REGISTRATIONS

- ASME Certified "HLW" Stamp/National Board
- All Models are California Code Compliant
- Water Heaters are Exempt from CSD1 / FM / GE GAP
- Canadian Registration Number (CRN)

Lochinvar LLC reserves the right to make product changes or improvements without prior notice. Dimensions are approximate and should not be used for construction purposes.



Lochinvar, LLC
 300 Maddox Simpson Parkway
 Lebanon, Tennessee 37090
 P: 615.889.8900 / F: 615.547.1000
[Lochinvar.com](https://www.lochinvar.com)

